

Overview - Get to know your Pandora

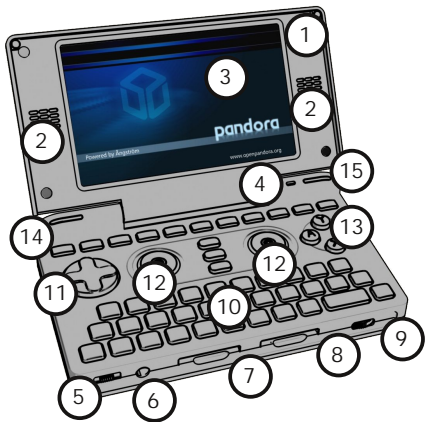

1 WiFi / Bluetooth® - Antenna

2 Speakers

3 Touchscreen LCD

4 Microphone

5 Power/Hold Switch
Slide right to power on or enable/disable powersaving
Click to the left to activate hold feature

6 Headphones

7 SDHC Card Slots
Both support up to 128GB cards

8 Volume Wheel

9 Stylus Slot

10 Keyboard

11 Directional Pad
Can be used for playing games or as cursor keys

12 Analog Controls
Two analog nubs for gaming or mouse use

13 Gaming Buttons
Also mapped to PgUp, PgDwn, Prior and Next

14 SD Activity, WiFi and Bluetooth®- LEDs

15 Power and Charge LEDs
Power LED indicates the system is active.

Dim Power LED indicates the system in powersaving mode.

Charger LED indicates a charging source is present.

A blinking charger LED indicates a low battery power.

Overview - Get to know your Pandora

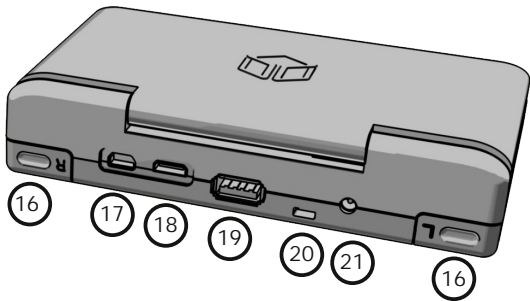

16 L/R Trigger Buttons

17 USB 1.1/2.0 OTG Port
Can also be used to charge the unit

18 Expansion Port
Provides UART, TV Out and Audio IN /
OUT

19 USB 2.0 Host Port
You need a USB Hub if you want to
connect USB 1.1 devices!

20 Hole for Wrist Strap

21 Power Connector
Only connect official adaptor

Power Saving on the Pandora

The default configuration of the Pandora has been done so that it saves as much battery power as possible.

This way you can use your Pandora up to 13 hours in normal operation, about 60 hours just for music listening and more than 100 hours if it just sits around idling.

However, it means that WiFi, Bluetooth and the USB-Host Port has been disabled.

Enabling it is simple: Either toggle it on/off via the System-Menu or use the small Quick-Settings-Tool sitting in the tray.

If you wish, you can go to Settings / Startup and enable or disable WiFi and the USB Host on startup.

Some important buttons and mouse usage

You can either use both nubs as mouse (default setup: Left nub moves the mouse, right nub does left click (move left), right click (move right), middle click (move down) or double click (move up)) or the touchscreen (click and hold for right-click).

You can change the nub-settings using Settings/Pandora Nub Configurator.

The DPad can be used as cursor keys while ABXY are mapped to Prior, End, Page Up, Page Down. The left shoulderbutton is mapped to Shift and the right to CTRL.

To move windows around without using the menu bar, press and hold the left shoulderbutton while using the touchscreen to move the window.

Some important buttons and mouse usage (continued)

In case your Pandora has a hard lockup (shouldn't happen, but can happen), press and hold the Pandora Button and flick the Power Switch.

If you move the Power Switch to the left positions, most inputs are disabled (ideal if you want to listen to music while you got it in your pocket).

If you hold the right shoulderbutton while you switch on the unit, you can access the Bootmenu which will offer various options (you can also boot an OS off your SD Card that way).

The Compose-Key is mapped to Shift + Enter. So to enter an "ö", for example, press Shift + Enter, after that "o" and Fn+s.

How to install games and programs

The Pandora OS only includes some basic tools. Stuff like games, emulators, webbrowsers, etc. have to be installed onto your SD Card. Doing so is easy: All you need to do is download the program as a .PND file and put it onto your SD Card into the correct directory.

/pandora/desktop: All PNDs in here show up on the desktop

/pandora/apps: All PNDs in here show up on the desktop and in the menu

/pandora/menu: All PNDs in here show up in the menu

/pandora/mmenu: All PNDs in here only show up in MiniMenu

So the first thing you should do on a freshly formatted SD Card is to create a directory named pandora and subdirectories named desktop, menu, apps and/or mmenu.

How to install games and programs (continued)

It's a good idea to give your SD Card a name (label), so that the mounted path will always be the same.

Another way to install games is to use PND-Store (included in the OS), which enables you to download games and apps directly with your Pandora.

The recommended way is to download and put PNDManager on your SD-Card. This awesome utility lets you browse the Pandora repository, installs or updates any game or app directly on your SD Card.

You will find it (and most other stuff) on <http://repo.openpandora.org/>

How to install games and programs (continued)

To remove a game, simply use PNDManager or delete the PND from your SD-Card.

Each game / apps saves its settings into a directory located in /pandora/appdata.

As long as you keep its directory, you will keep the settings. So you could delete a PND, copy it back later and you'd still have all your settings and saved games.

You can also reset a game or app back to its default settings by deleting the corresponding directory in /pandora/appdata

How to install games and programs (continued)

Some games require datafiles of original games to be put into the appdata-directory.

Please check the documentation of these games for more information (can be found in the Startmenu under "Documentation")

Usually, if well coded, these games tell you that the data files are missing. But that's not always the case, sometimes they simply don't run.

A logfile is being put into `/tmp/pndrun_<appname>.out`. You can view it using the terminal or any text editor. It might contain clues what's going wrong in case some game doesn't want to start.

More information...

That's the end of our little Quick-Start guide on the Pandora. If you have any further questions, want to check for the latest software, want to help out with development or just have a nice conversation with other Pandora-Users, be sure to check out our webboards at <http://boards.openpandora.org/>

We hope you enjoy your little new toy.
You can do a lot more with it than you probably think right now.